

HUSKY 620

Product Guide



ROUGH TERRAIN HYDRAULIC CRANE

Features

- **MAX. CAPACITY (Outriggers)** - 20.0 Tonnes at 3m Radius (85% Rating) 360° Slew
- **MAX. CAPACITY (On Tyres)** - 16 Tonnes Over Front
- **BOOM** - 3 section Rectangular 8.8m - 21.2m
2 section Rectangular 8.5m - 14.7m (Optional)
- **MAX. ROAD SPEED** - 33 kmph
- **CARRIER** - 4 x 4 Wheel Drive with 4 Wheel Steer

Superstructure Specification

BOOM

8.8m - 21.2m three section, full powered, fully synchronized boom by means of single double acting ram and lacing chain to ensure proportional telescoping of boom sections under single joystick position control.

Maximum Tip Height: 23m

BOOM ELEVATION

Single double acting hydraulic cylinder mounted on large diameter bushes. Fitted with combined cartridge type externally mounted hydraulic lock and counterbalance valve to prevent ram collapse in the event of hydraulic failure and provide positively controlled derricking out.

BOOM ANGLE

Maximum 76°, Minimum -2°.

SUPERSTRUCTURE FRAME

Fabricated from high tensile steel plates and sections. Mechanical superstructure lock operated from cab.

SLEW SYSTEM

Hydraulic motor driving a pinion through a double reduction gear unit. The pinion meshes with an externally cut slew ring 360° smooth and precise continuous rotation. Spring applied hydraulically released multi plate brake. Free slew facility provided.

SLEW SPEED

Maximum 2.0 RPM (Unladen) for controlled operation.

HOIST SYSTEM

Hydraulic motor driving hoist barrel via reduction gear unit. Fitted with counterbalance valve for controlled lowering of the load. Spring applied hydraulically released multi plate brake. Limit switch provided to prevent over-lowering.

Non Spin Hoist Rope: 13mm dia. & length 115m.

Line Speed: Top layer 65m/min (Max) Unladen.

Maximum Permissible Line Pull: 3125kg.

HOOK BLOCK

20.0 Tonnes; 4 Sheaves.

COUNTERWEIGHT

Integral with superstructure. Weight - 2500kg.

OPERATOR'S CAB

Totally enclosed steel construction, full vision type tropical cab. Ergonomically positioned joystick levers on either side of seat control all craning motions. Instrumentation located at console. Seat adjustable on slides & automotive type steering wheel provided. All windows fitted with toughened safety glass, lockable sliding door, cab interior light. Pantograph type electric wiper on front windscreen. Electric horn and fan.

CRANE CONTROLS

Joystick operating controls for slew, telescoping, hoisting and derricking with independent or simultaneous operation of crane motions. Engine speed governed by pedal control. Electric rocker switches for control of hydraulic outriggers. Override control switch provided.

TRAVEL CONTROLS

Steering wheel operates a steering unit to control the hydraulic cylinder on front axle. Independent hydraulically powered steering on rear axle by twin switches in operator's cab. Gear shift mounted on steering column. Service brake operated through foot pedal and parking brake operated through graduated hand brake valve.

INSTRUMENTATION

Audio and visual warning for engine oil pressure, engine coolant temperature provided. Visual warning for alternator, rear steer, parking brake and directional indicators provided. Air pressure gauge and hour meter gauge provided.

LOAD MOMENT INDICATOR

Provides radius and hook load indication, visual indication of approach to overload, visual and audible indication of overload condition. Motion cut equipment operated by safe load indicator. Cuts derricking out, telescoping out or hoisting motion when overload condition is reached.

HYDRAULIC SYSTEM

Load sensing hydraulic system provides adequate pressure and flow of hydraulic oil for independent crane operation.

Pumps

Load sensing variable displacement axial piston pump provided.

Control Valves

All control valves mounted on side of superstructure offering easy accessibility. Load sensing, load sharing control valves operated by joystick controllers from operator's cab. Electro hydraulic solenoid valves control hydraulic outriggers.

Filters

Return line filter with replaceable cartridge having full flow with by-pass protection and clogging indicator.

Reservoir

273 liters with return line type filter provided.

Oil Cooler

Electrically driven thermostatically controlled oil cooler for maintaining safe operating temperature of hydraulic system.

OPTIONAL EQUIPMENT

Telescopic Boom : 8.50m to 14.70m two section fully powered boom by means of a single double acting ram

Lattice Boom Extension : 8.0m swing round lattice boom extension to give a maximum combination of 29.2m.

Lifting Capacities - 3 Section Boom 85% Rating (Metric Tonnes)

Main Boom Duties on Outriggers - Through Full 360° Slew

Radius (in Meters)	Boom Length					
	8.80m Fully Retracted	8.80m to 11.50m	11.50m to 14.50m	14.50m to 17.50m	17.50m to 20.00m	20.00m to 21.20m
3.00	20.00	13.65	13.35			
3.50	17.50	13.65	12.95	8.75		
4.00	15.30	13.65	12.45	8.45		
4.50	13.50	12.80	11.95	8.25	6.50	
5.00	12.00	12.00	11.50	7.95	6.30	5.20
6.00	9.80	9.80	9.80	7.40	5.95	4.95
7.00		8.45	8.45	6.90	5.60	4.70
8.00		6.80	6.80	6.35	5.30	4.50
10.00			4.70	4.70	4.70	4.00
12.00			3.40	3.40	3.40	3.40
14.00				2.65	2.65	2.65
16.00					2.10	2.10
18.00						1.65

8.80m to 21.20m Boom + 8.00m Lattice Extension		
Maximum Radius (in Meters)	Capacity 360° Slew Circle	Laden Boom Angle
8.00	1.30	73.5°
10.00	1.20	69.5°
12.00	1.10	65.5°
14.00	0.95	61.5°
16.00	0.85	57°
18.00	0.75	52°
20.00	0.65	47°
22.00	0.60	41°
24.00	0.55	34°
26.00	0.50	25.5°
Total Length 29.20m		

Note : When the lattice extension is fitted in the operating position main boom capacities must be reduced by 0.76 tonne.

Free on Wheels Duties

Radius (in Meters)	14.00 x 25-24 PR Tyres - Tyre Inflation Pr. 8.1 kg/cm ²		
	Static		Upto 5 km/hr Over Front
	Over Front	360° Slew	
2.75	16.00a	11.15a	12.65a
3.00	14.80a	9.80a	11.90a
3.50	12.60a	7.65a	10.55a
4.00	10.35a	5.85a	9.45a
4.50	8.35a	4.75a	8.05a
5.00	6.65a	3.90a	6.65a
6.00	4.80b	2.70b	4.80b
7.00	3.85b	2.20b	3.85b
8.00	3.00c	1.65c	3.00c
10.00	2.05c	1.05c	2.05c
12.00	1.35d	0.55d	1.35d
14.00	1.00d		1.00d

Maximum permissible boom lengths : a = 8.80m, b = 11.50m, c = 14.50 m, d = 17.50m

Notes for Lifting Capacities

WARNING: THIS CHART IS ONLY A GUIDE. The notes below are illustration only and should not be relied upon to operate the crane. The individual crane's load chart, operating instructions and other instruction plates must be read and understood prior to operating the crane.

- All rated loads have been tested to meet minimum requirements of IS:4573-1982 Specification for Power Driven Mobile Crane and do not exceed 85% of the tipping load on outriggers as well as on rubber as determined by SAE J765 OCT80 Crane Stability Test Code.
 - Capacities above the thick line are based on factors other than stability. Hence crane tipping must not be relied upon as a guide to the capacity limitation.
 - The rated load includes weights of hook block, slings and all similarly used load handling devices. When more than minimum required reeving is used, the additional rope weight shall be considered part of the load. Load ratings are based on freely suspended loads. No attempt shall be made to move a load horizontally on the ground in any direction.
 - Capacities quoted are based on freely suspended loads with the four telescoping outriggers fully extended and down so that tyres are raised clear of the ground with the machine accurately leveled on firm and uniformly supported surfaces. It may be necessary to have structural supports under the outrigger floats to spread the load, to a larger bearing surface.
 - Practical safe working loads are dependent on the supporting surface, wind and other factors affecting stability, hazardous surroundings experience of personnel and proper handling of the load all of which must be taken into account by the operator.
 - When either boom length or radius or both are between values listed, the smallest load shown at either the next larger radius or boom length shall be used.
 - Capacities shown in the duty chart must not be derricked below 12° boom angle.
 - When lattice extension is fitted, the boom must be fully retracted for boom angle less than those shown in the duty chart.
 - Angle based capacities are determined by laden boom angles given and not by radius. Radii quoted refer only to fully extended booms.
 - For the main boom fully extended with 8.0m fixed extension in working position, the boom angle must not be less than 25.50°, since loss of stability will occur causing a tipping condition. This warning also applies for boom extension erection purposes.
 - Do not move the crane with boom extension or jib erected.
 - Handling of other equipment with the boom is not authorized except with equipment furnished and installed by TIL Ltd.
- FREE ON WHEELS**
- Capacities quoted are based on freely suspended loads with the machine standing on a firm, level and uniformly supporting surface and tyres inflated to their correct pressures. It may be necessary to have structural supports under the tyres to spread the load, to a larger bearing surface.
 - For pick and carry operation, boom must be centered front of the machine with mechanical slew lock engaged and all lockouts must be functioning before lifting on rubber.
 - Over front capacities must only be lifted within a maximum slewing angle of 2.1/2° either side of crane center line and are valid only up to a maximum travel speed of 5km/hr.
 - On rubber, lifting with boom extension is not permitted.

Height of Lift - 3 Section Boom

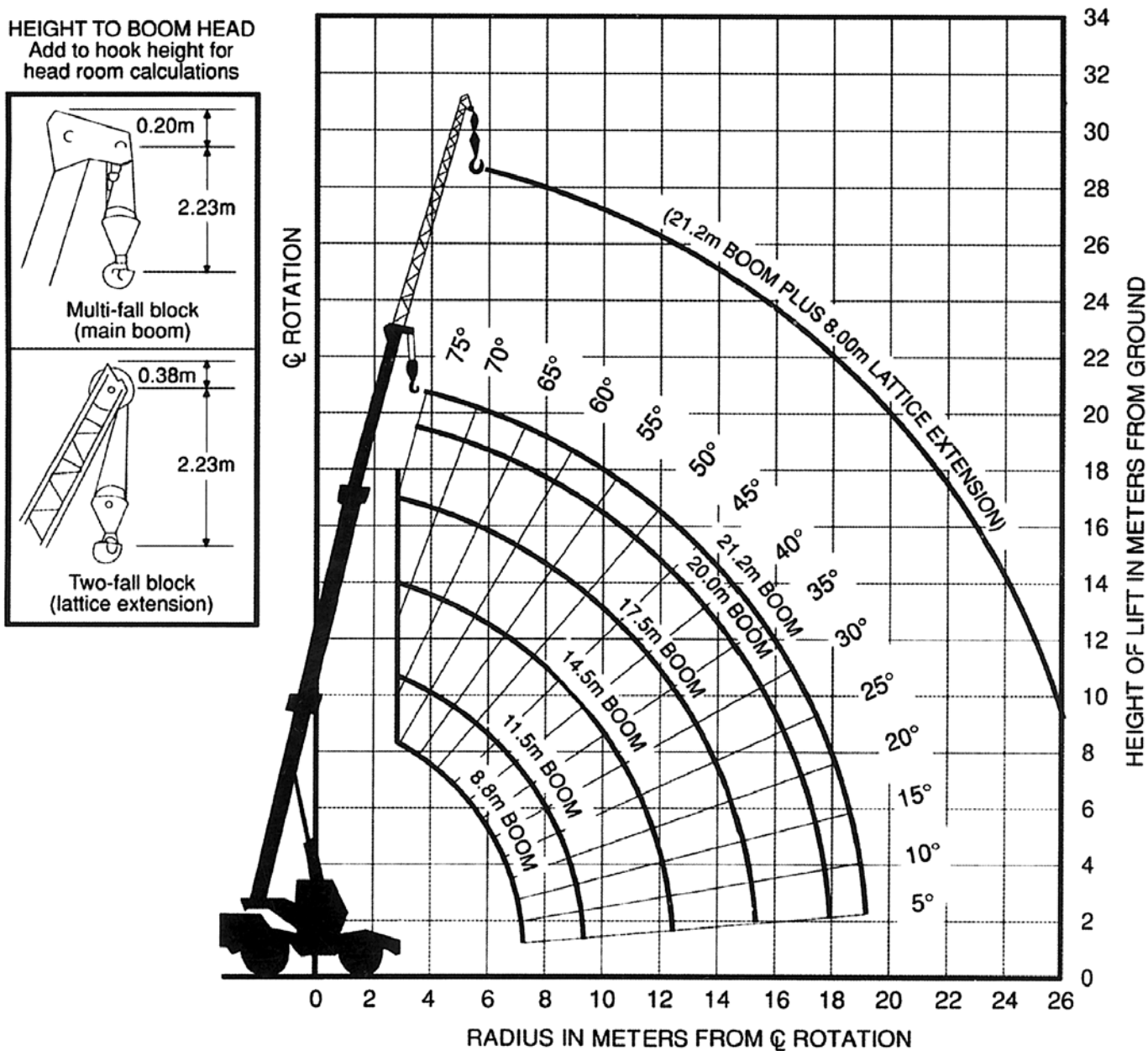

Note: The above heights of lift and boom angles are based on a straight (unladen) boom and allowance should be made for boom deflections obtained under laden conditions.

The above heights of lift are for multi-fall hookblocks on main boom and single-fall on lattice extension. Add 0.46m, if single-fall block is used in place of multi-fall or deduct 0.46m if multi-fall is used in place of single-fall.

HUSKY 620

Hookblock Capacities and Weights - Tonnes

No of Falls	8	7	6	5	4	3	2	1
Permissible Load	20.00	18.15	16.20	14.26	11.53	8.73	5.87	2.95
Weight of Hook block	0.20	0.20	0.20	0.20	0.20	0.20	0.10	0.09

Carrier Specification

FRAME

High strength alloy steel welded box section with integral outrigger housings.

OUTRIGGER SYSTEM

Four hydraulically operated outriggers with graded telescoping beams with vertical jacks fitted with integral holding valves. Vertical jacks fitted with removable, stowable outrigger feet. Outrigger controls located in operator's cab. Independent control of all outriggers with individual beam and jack operation.

ENGINE

Ashok Leyland H6C4 Engine Series, 160 HP @ 2200 RPM
Max. Torque - 650Nm @ 1400-1600 RPM
Emission : BSIV-CEV

FUEL TANK

Capacity 273 liters.

ELECTRICAL SYSTEM

Two 12 Volt-batteries, 24 Volt lighting equipment including two dipping headlights, side, tail and stop lights and flashing direction indicators.

DRIVE

4x4 / 4x2 wheel drive with four wheel steer.

STEERING

Fully independent power steering :

Front : Full hydraulic controlled by steering wheel.

Rear : Separate steering of rear axle by means of a rear steer switch in operator's cabin.

Provides infinite variations of 4 main steering modes - front only, rear only, crab and coordinated.

Automatic steering reversal. Rear wheel steer indicator provided.

TRANSMISSION

Engine mounted full power shift transmission with 6 forward and 6 reverse speeds. Provides front axle disconnect for 4 x 2 travel.

AXLES

Front: Steering / driving planetary axle with differential and planetary hub reduction solidly mounted to the chassis frame.

Rear: Steering / driving axle with differential and planetary hub reduction, pivot mounted at center of the chassis frame. Oscillation locks operated from cab.

TYRES

14.00 X 25-24PR earthmover tyres.

BRAKES

Service: Foot operated compressed air over hydraulic pressure brakes.

Parking and emergency: Spring operated, air / hydraulic released transmission brake.

MAXIMUM SPEED

33 kmph.

GRADEABILITY

45% unladen

GROSS VEHICLE WEIGHT AND AXLE LOADS (approx)

Front : 11340 kg (with 8m lattice)
10425 kg (without 8m lattice)

Rear : 8870 kg (with 8m lattice)
8980 kg (without 8m lattice)

GVW : 20210 kg (with 8m lattice)
19405 kg (without 8m lattice)

Optional Weights (approx.)

Auxiliary Hoist : 350 kg
Fixed Lattice : 800 kg
Man Carrying Basket : 550 kg

MISCELLANEOUS STANDARD EQUIPMENT

Full width Steel Fenders
Rear View Mirror
Back-up alarm
Front Stowage Well
Tool Kit

OPTIONAL EQUIPMENT

- Auxiliary Hoist
- 360 deg. Beacon light
- Man Carrying Basket
- AC Cab
- Protective Super Cab
- Centralized Lubrication System
- Fire Suppression System
- Fire Extinguisher
- Spark Arrestor
- Tow Hook

GA Drawing

HUSKY 620

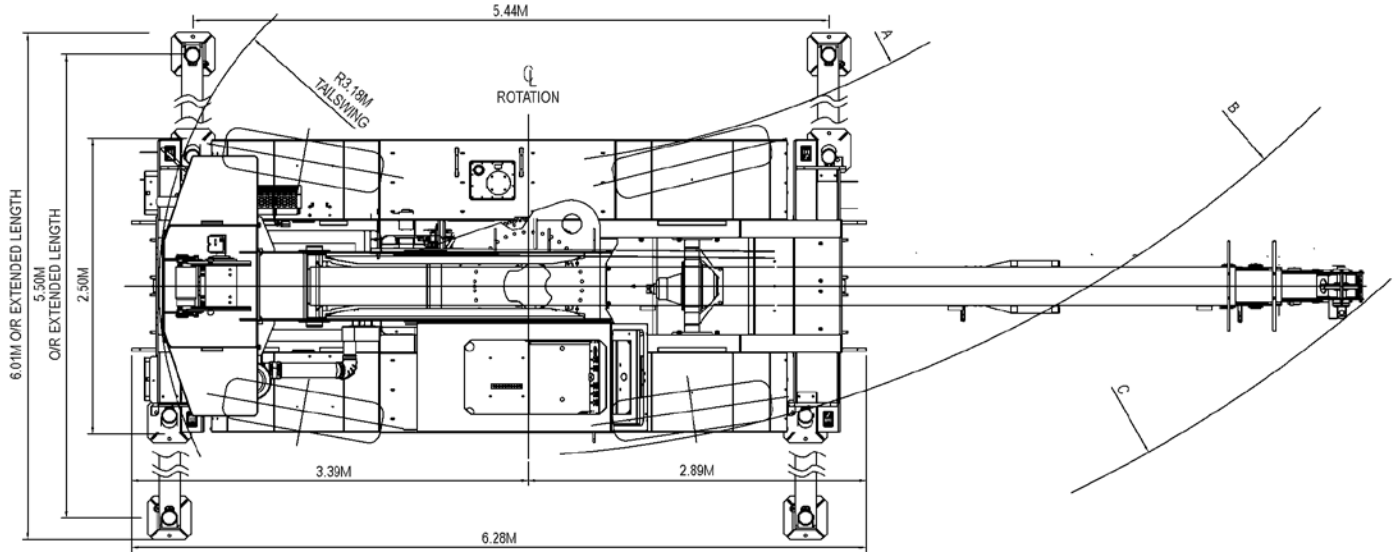

Tyre Size	Kerb to Kerb Inner 'A'		Kerb to Kerb Outer 'B'		Wall to Wall 'C'		Ground Clearance	Approach and Departure in °s
	2 wheel steer	4 wheel steer	2 wheel steer	4 wheel steer	2 wheel steer	4 wheel steer		
14.00 x 25 x 24	7.00m	3.15m	9.25m	5.50m	11.4m	7.85m	0.50m	30°

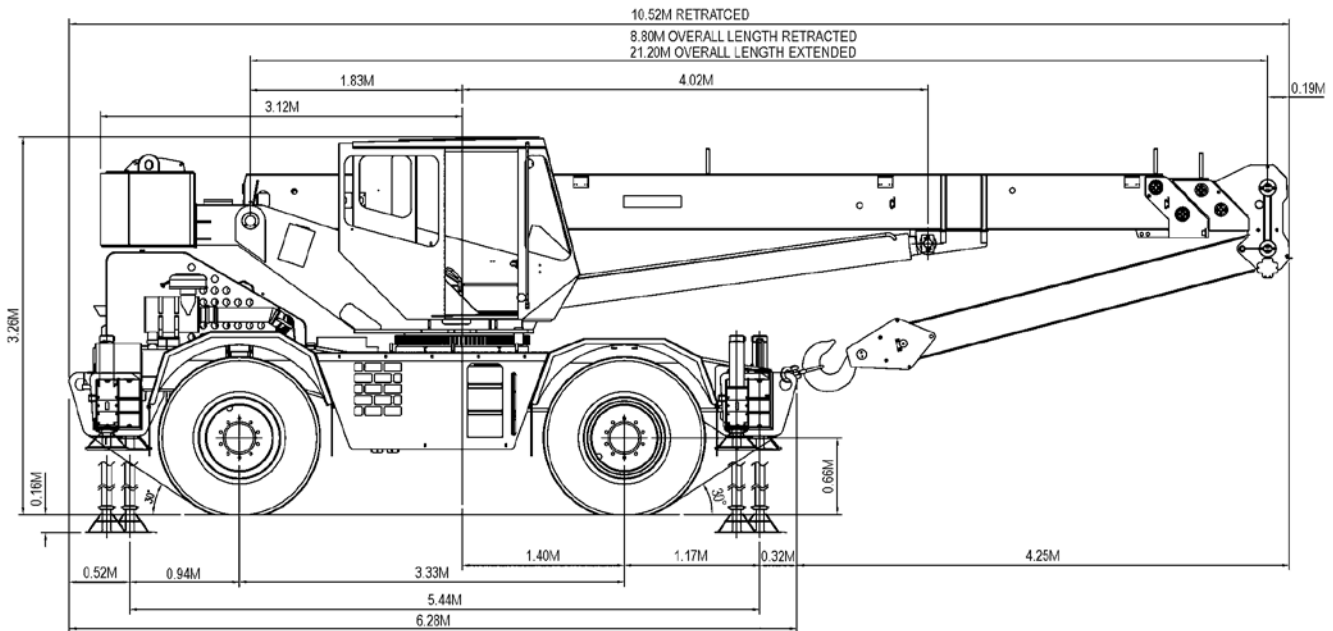

HUSKY 620

Constant improvement and engineering progress make it necessary that we reserve the right to make specification, equipment and price changes without notice. The photographs/drawings in this document are just for illustrative purpose which may include optional equipment and accessories, which can be provided at an additional cost on request.

TIL Limited

CIN: L74999WB1974PLC041725

Registered & Corporate Office:

1, Taratolla Road, Garden Reach, Kolkata - 700024
Phone: + 91 33 2469 3732-6 / 6497 | 6633 2000 / 2845
Mobile: +91 9831839025 | +91 9831054573
Fax: + 91 33 2469 2143 / 3731
Email: Mhg.Er@tilindia.com | mktg-til@tilindia.com



CHENNAI

TIL Limited
Jhaver Plaza, 7th Floor 1-A Nungambakkam
High Road
Chennai 600 034, Tamil Nadu
Phone: +91 044 6670 3000 / 3010
Mobile: +91 9618562333 | +91 9790973502
Fax: +91 44 2827 9681
Email: chennai.til@tilindia.com

DELHI NCR

TIL Limited
Plot 11, Site No.IV
Sahibabad Industrial Area
Ghaziabad 201 010 U.P.
Phone: +91 120 277 8735 / 8736 / 7468
Mobile: +91 9971091610 | 9903842544
Fax: +91 120 277 7467
Email: MHGMarketing.Sahibabad@tilindia.com | mhgcs.Sahibabad@tilindia.com

DELHI

TIL Limited
302 Ansal Bhawan
16, Kasturba Gandhi Marg, New Delhi 110 001
Phone: +91 11 2331 1607 / 8046 / 9248 | 2335 0250 / 0255
Fax: +91 11 2331 3263
Email: til.delhi@tilindia.com

KAMARHATTY

TIL Limited
517, Barrackpore Trunk Road
Kolkata 700 058
Phone: +91 33 2553 1352 / 1882 | 6633 4000
Fax: +91 33 2553 2546 / 5971
Email: MktDept.KMT@tilindia.com | til.kmt@tilindia.com

KHARAGPUR

TIL Limited
Vill. & P.O. Changual, Kharagpur
Dist: Paschim Medinipur 721 301, West Bengal
Phone: +91 32 2266 1101

MUMBAI

TIL Limited
A - 606, A Wing, 6th Floor,
215 Atrium, Andheri - Kurla Road,
Andheri (East), Mumbai 400059, Maharashtra
Phone: + 91 22 4969 1169
Mobile: +91 8850971609
Email: Mumbai.TIL@tilindia.com | Mumbai.Custsupp@tilindia.com

TIL has a pan-India network of offices with service engineers located in the close proximity of jobsites.

Toll Free No: **1800 266 1535**

www.tilindia.in

Technical Specification TIL / HUSKY 620 / 1119. This cancels Technical Specification TIL / Husky 620 / 0718